



CRA MOTOR MODULE

A. Motor Module disassembly:

Step 1: Remove motor side cover: Unscrew the circuit breaker from the end of cover, and then unscrew the 4 pcs M6 socket head screws to remove the cover. See Figure 1.

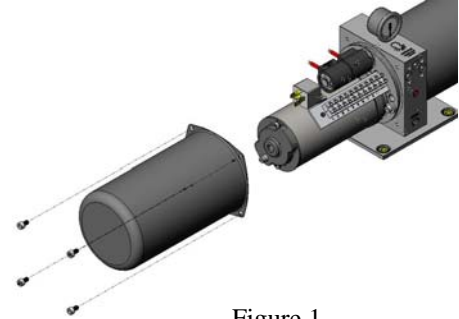

Figure 1

Step 2: Unscrew 3 pcs M6 socket head screws on the manifold, remove the CRA motor module completely. The control relay locates on the rear end of the motor module if your module is the old style. See figure 2.

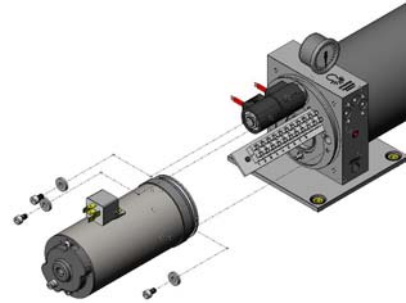

Figure 2

Step 3: Remove and discard the roll pin from the manifold. See Figure 3.

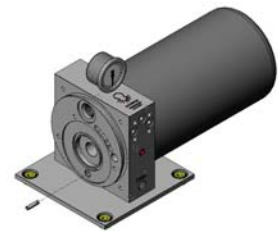

Figure 3

B. Replace new Motor Module

Step 4: Reassemble the control relay on top of the motor module by a #8-32 screw. See figure 4.

Step 5: Assemble the motor module to manifold, make sure the relay is on top side. See figure 2.



Figure 4

Step 6: Assemble the cover back and final test the whole system. See figure 1.