



RFB MODULE - CALIBRATION PROCEDURE – ROTARY MECHANICAL DRIVE

APPLICABLE MODELS

- a. All styles of Octopus rotary mechanical drives factory equipped with RFB module part # OC15SUK0A THRU F. Suffix R in basic part number. Note that RFB modules are matched to specific autopilot models.

REQUIRED PARTS:

- a. Philips screwdriver for # 8-32 screw.

MECHANICAL CALIBRATION PROCEDURE

1. Before installing the drive unit into the vessel, disassemble the RFB module from the drive housing, by removing 2 attach screws.
2. Install the drive unit into the vessel and install the steering cable following the drive installation guide.
3. Complete the electrical hook up of the drive following the drive-autopilot installation guide.
4. Complete the electrical hook up of the RFB module following the drive-autopilot installation guide.
5. Center the gear on the RFB module by aligning the red paint mark on the gear with the red paint mark on the housing as shown in underside view graphic below.
6. By turning the steering wheel of the helm unit, centre the rudder. Note that on power assisted steering systems, you may need to run the engine to achieve this.
7. Reassemble the RFB module to the drive housing and install and tighten the 2 attach screws. Ensure that the mesh between the RFB module and the drive gear is not excessive.
8. See autopilot installation guide for instructions on additional software controlled RFB fine calibration and HO limitation.

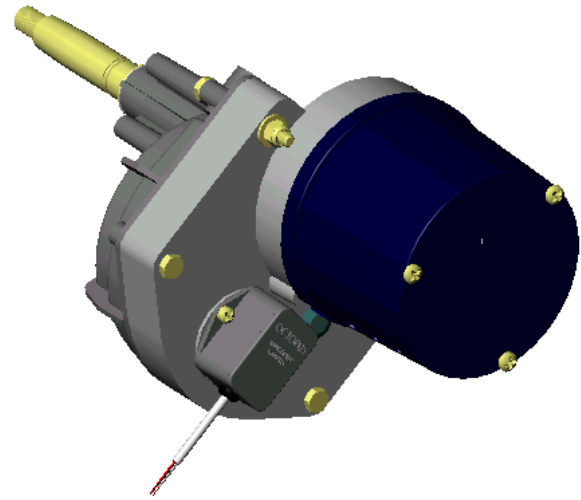

COMPLETE INSTALLATION



RFB MODULE

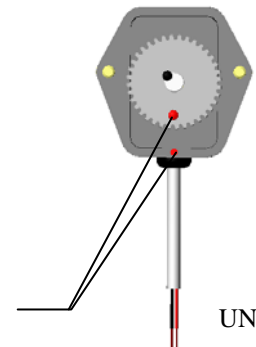

ALIGN 2 RED DOTS VERTICALLY

UNDERSIDE VIEW