



## FLOW ADJUSTMENT PROCEDURE - REVERSING PUMP

### A. OVERVIEW:

1. Octopus reversing pumps can supply oil flow from the maximum rated down to approximately 40% of maximum rated. The flow adjustment mechanism is simple and does NOT use any orifice or other flow-restricting device, which results in wasted energy and a reduction in pumpset life.
2. Octopus reversing pumps are set at maximum flow in the factory. This flow rate can be adjusted in the field by using a 4mm A/F allen key and following the procedure described below.

### B. SYSTEM PARAMETERS

1. Steering Cylinder Speed – Units are: seconds (s)
  - a. For optimum performance, autopilot electronics usually require that the speed of rudder corrections be within a set speed range. This set speed range is usually around 13-15 seconds and is measured by timing the rudder from full hard over Port to full hard over Starboard while sitting in still water at dockside, (see your autopilot manual to determine the speed range for your vessel).
  - b. Some sea conditions, performance requirements or hull/steering response characteristics may require different rudder speed settings. (see your autopilot manual).
2. Steering Cylinder Volume (Displacement) – Units are: cubic inches (ci) or cubic centimeters (cc)
  - a. The steering cylinder volume (or displacement) is usually calculated from the physical dimensions of the cylinder. This volume is equal to the amount of oil that must be supplied by the pump to fully extend the cylinder (from fully retracted) or to fully retract the cylinder (from fully extended). For pump sizing purposes this fully retracted – fully extended volume equals the rudder HO to HO.
  - b. For steering systems with twin steering cylinders, both cylinders must be considered when pump sizing.
  - c. Similar sized vessels may NOT have similar sized steering cylinders; they can vary due to space limitations or configuration etc. The volume of oil required to move the rudder from HO to HO as described above is the only way to determine the oil flow requirement and therefore the size of pumpset flow that is required.
3. Pumpset Sizing
  - a. Pumpsets are conventionally rated for flow in cc per minute (or ci per minute), **TO COMPENSATE FOR THIS CONVENTION**, the steering cylinder volume **MUST** be multiplied by 4 (as 13-15 seconds is approximately  $\frac{1}{4}$  of a minute) to convert it to an approximate autopilot cc per minute (or ci per minute) flow rate specification.

$$\text{STEERING CYLINDER VOLUME} \times 4 = \text{AUTOPILOT FLOW RATE PER MINUTE}$$

- b. After converting the steering cylinder volume into a flow rate per minute specification, it is simply a matter of comparing the pumpset maximum flow rate to the autopilot flow rate required and ensuring that the pumpset maximum flow rate is either **EQUAL** to or **GREATER THAN** the autopilot flow required.
- c. If the pumpset maximum flow rate is greater than the autopilot required flow rate, the flow rate of the pumpset must be adjusted following the procedure below.

## FLOW ADJUSTMENT PROCEDURE - REVERSING PUMP Continued

### C. PUMP FLOW ADJUSTMENT PROCEDURE

1. If your steering system is pressurized with air, it should be de-pressurized during the flow adjustment procedure.
2. Crack and loosen by 2 full turns the M5 allen screw that holds the left hand pump body lug onto the front endshield of the motor. See graphics 1 & 2.

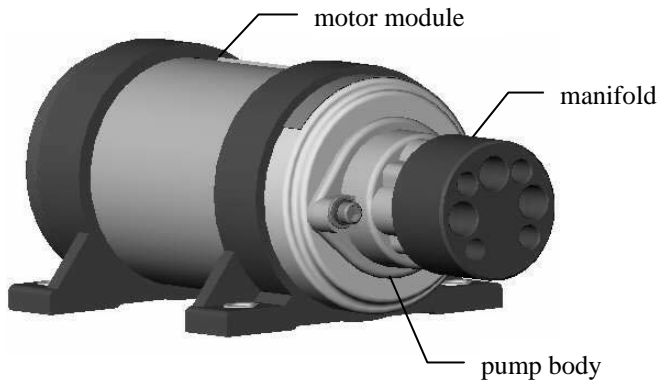

GRAPHIC 1

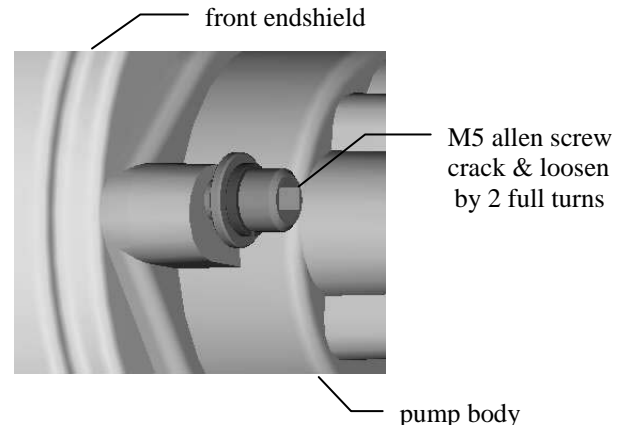

GRAPHIC 2

3. Crack and loosen by 2 full turns the M5 allen screw that holds the right hand pump body lug onto the front endshield of the motor. See graphics 3 & 4.

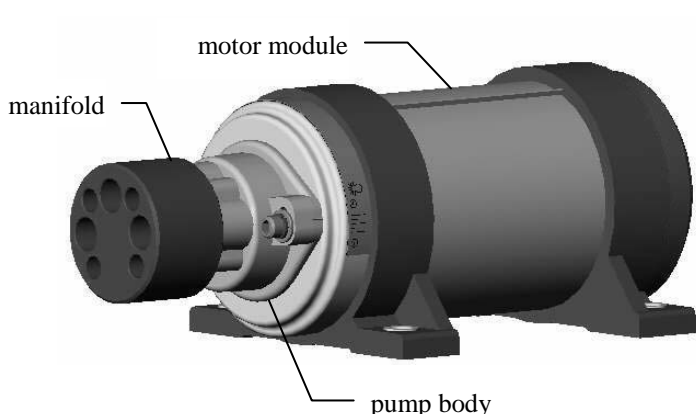

GRAPHIC 3

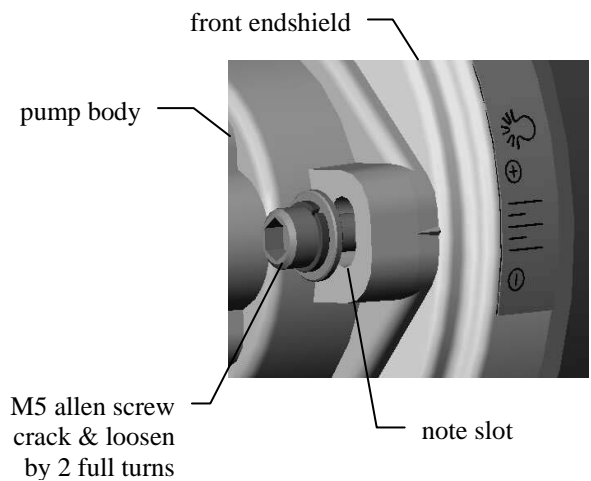

GRAPHIC 4

## FLOW ADJUSTMENT PROCEDURE - REVERSING PUMP Continued

4. Note the following features: See graphics 5 & 6
  - a. Flow rate scale label located on right hand side of motor module on front end shield.
  - b. Raised marker cast onto right hand lug of pump body.
  - c. Slot under head of right hand allen screw.

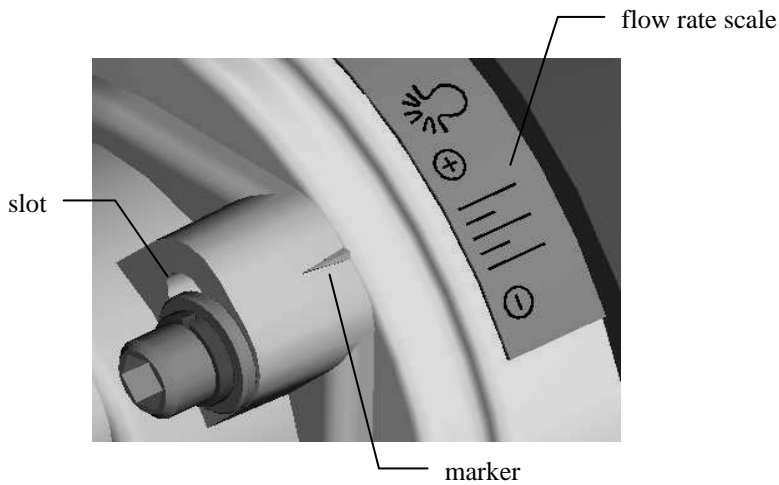

GRAPHIC 5  
Maximum Flow Setting

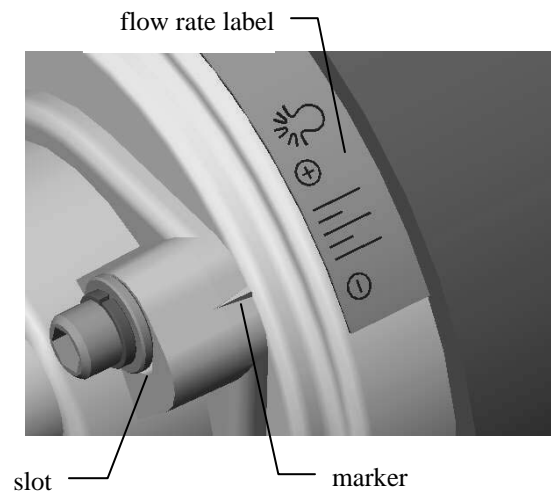

GRAPHIC 6  
Minimum Flow Setting

5. Using hand force, slide the right hand side of the pump body down to a lower setting on the flow rate scale. Note it is possible that due to corrosion or distortion damage from over tightening, the walls of the slot may interfere with the body of the allen screw. If this is the case, additional force may be required or it may be necessary to clear this interference with a small file.
6. Re-tighten the 2 x M5 allen screws using a 4mm A/F allen key.
7. If your steering system is pressurized with air, it should be now be re-pressurized.
8. It may be necessary to try several settings to get the best autopilot performance.