

INSTALLATION MANUAL

OCTOPUS Type RS
Sailboat Drive

OC15276



Revision History

Revision	Description
A	Released in Book Format

© 2009 Octopus Products Inc. All rights reserved.

The information contained in this document is the sole property of Octopus Products Inc. Any reproduction in part or whole without the written permission of Octopus Products Inc. is prohibited. Octopus Products Inc will nor be liable for errors contained herein or for incidental or consequential damages in connection with the furnishing, performance or use of this document.

Contents

A1	System Overview	6
A2	IMPORTANT SAFETY INFORMATION	7
A3	Installation Planning	9
B	Planning	
B1	Determine Mounting Site for Drive Unit	9
B2	Determine Mounting Site for Connection Kit	11
B3	Determine Routing Path for Steering Cable	12
B4	Determine Length of Custom Steering Cable	13
C	Installation	
C1	Drive Unit – Steering Cable – Spent Cable Tube	14
C2	Cable Connection Kit	17
C3	Electrical Connections	19
C4	Mechanical Calibration	20
D	Dockside Set Up	21
E	Sea Trial	21
F	Maintenance	21
G	Steering Cable Replacement	21
H	Installation Envelope & System Specification	22

OCTOPUS – Type RS Sailboat Drive

A1. SYSTEM OVERVIEW:

1. The Autopilot Drive System makes it easy and economical to install an automatic pilot on small to medium size sailboats with access to a quadrant or tiller. The drive system is powerful and fast - capable of delivering over 450Nm/ 300lbs of cable thrust, with a normal H.O. to H.O. time of 12-15 seconds.
2. The system comprises of a drive unit, a steering cable and a connection kit. The drive unit can be installed in any convenient location. The steering cable and connection kit transmit the steering forces to the quadrant or tiller. Standard system steering cable length is 6 feet (2m) – other lengths available from factory. The drive unit has a drive motor and solenoid clutch which allows hand steering when disengaged. The drive unit also has a built in adjustable thrust limiter and an integral rudder feed back (RFB) device.

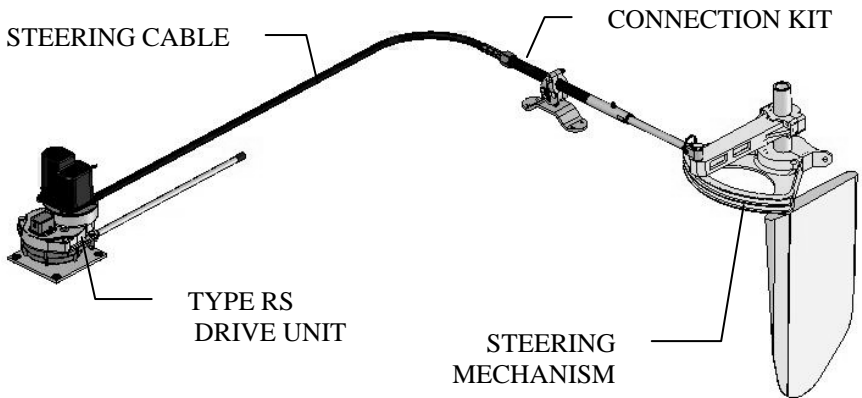

3. The Type RS Drive is designed to produce a maximum cable push/pull of over 450Nm/300lbs, which requires a peak power of 90 watts. This makes the unit capable of handling the vast majority of medium size sailboats up to 6500Kg/14300lb displacement fully laden and 11m/37ft length.

Note: The definition of Fully Laden = The displacement of the yacht including all added accessories and crew.

A2. IMPORTANT INFORMATION

Ensure that the Helmsperson is made aware of the three following safety features when using the Autopilot.

- 1. Drive ‘Manual Release’**
- 2. Drive ‘Manual Override’**
- 3. Drive ‘Quick Release’**

1. MANUAL RELEASE

A ‘manual release’ feature is included in the drive in case the Autopilot is switched to manual mode by mistake creating a dangerous manoeuvre while under sail on a sailboat or violent movement of the steering wheel on a Power Boat due to propeller action or a trim issue.

The drive unit will maintain the clutched “engaged” when the Autopilot is switched to “manual” mode. This helps to stop uncontrolled boat swing, violent steering wheel movement and potentially dangerous manoeuvres.

Manual Release Procedure

The wheel or tiller is required to be moved slightly to disengage the drive. A small joggle action (turning the wheel from side to side) will release the clutch and allow manual control.

IMPORTANT

Under normal use the helmsperson should always be ready to take manual control of the yacht when the Autopilot is returned to manual mode.

2. MANUAL OVERRIDE

In the event of **UNCONTROLLED** automatic steering or other **EMERGENCY** situations, automatic return to **MANUAL** steering is provided through the operation of a thrust limiter. It is **STRONGLY** advised that the helmsperson be formally familiarized with this **MANUAL OVERRIDE** procedure.

Manual Override Procedure. The helmsperson can overcome the steering action of the drive unit by exerting force on the steering wheel in the opposite direction to the drive. With this action the drive unit thrust limit will ‘slip’ allowing the helmsperson to take control.

3. QUICK RELEASE

The Cable end that attaches to the steering quadrant or Tiller arm has a quick release pin that can be used to disengage the cable from the main steering system therefore releasing the Autopilot drive. It is **very important** that the helmsperson is formally familiarized with the location of this during any passage.

To operate – remove hairpin from clevis pin and pull our clevis pin using attached chain. Note - there may be some pre-load on the clevis pin.

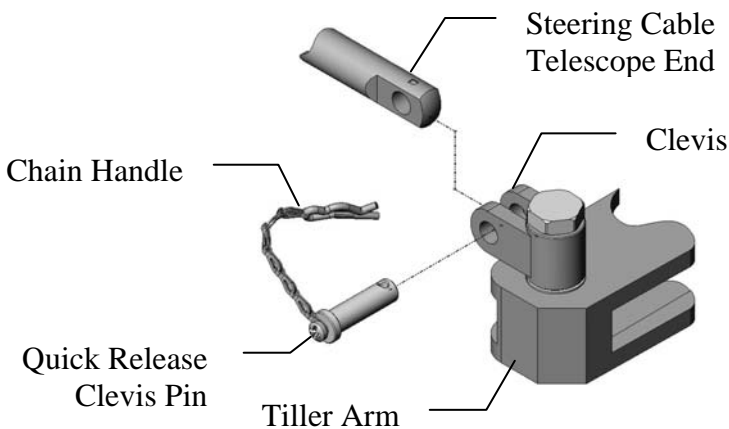

A3. INSTALLATION PLANNING:

When planning an installation, it is recommended that you follow 3 or 4 steps:

- STEP 1: Determine mounting site for drive unit.
- STEP 2: Determine mounting site for connection kit.
- STEP 3: Determine routing path for steering cable.
- STEP 4: Determine custom steering cable length (only if required).

B1. STEP 1 – Determine Mounting Site for Drive Unit

1. The mounting site should provide adequate space to accommodate the drive envelope including the entry and exit points for the steering cable. The drive can be mounted at any angle. See detailed graphics of drive envelope and mounting samples below. Note that no access for maintenance purposes is required.

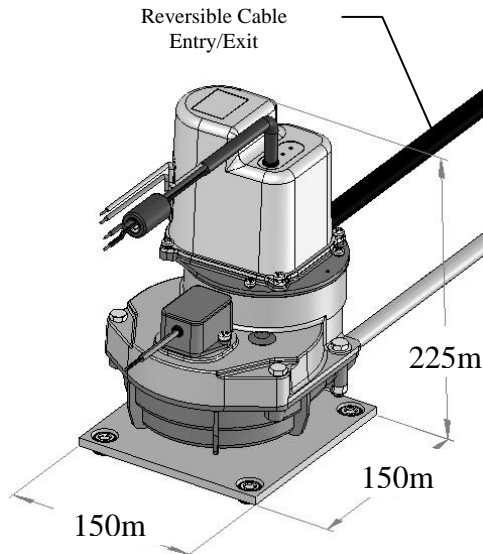

2. The selection of the steering cable entry/exit port does **NOT** have a preference. To provide more flexibility for routing the steering cable, the entry/exit port arrangement can be reversed. If ports are reversed, the steering direction will also be reversed. To compensate for this, the Autopilot software or motor wiring can be adjusted.

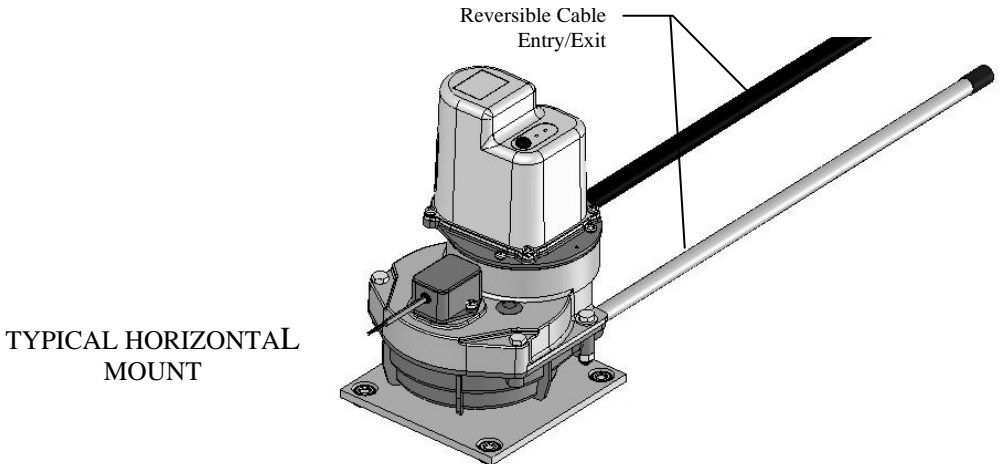
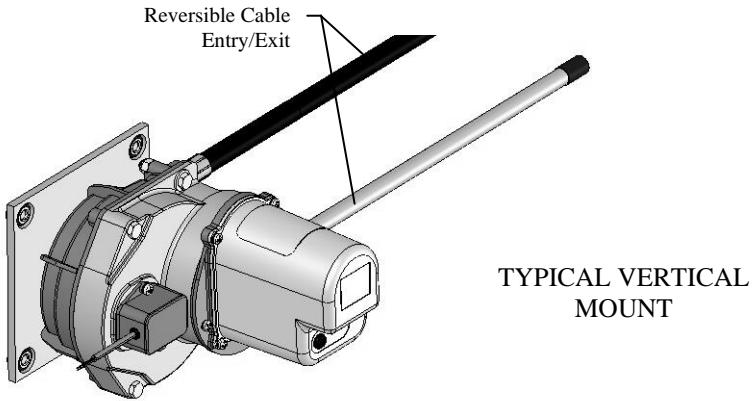

B2. STEP 2 – Determine Mounting Site for Connection Kit

1. The Connection Kit must be mounted to stable hull structure. Any orientation is acceptable as long as the HO positions do not force the connection kit beyond its rotation limits. Ideally the connection kit should be mounted so that the thrust from the steering cable is perpendicular to the tiller at mid stroke. It is acceptable to mount the connection kit without using the base plate. The clevis bracket can be mounted to a separate tiller arm or directly to the quadrant if a suitable site is available. A thru hole 0.375 diameter is required to attach the shoulder bolt that is supplied with the standard clevis.
2. See Page 8 for detailed guide and connection options.
3. Some Steering Systems may have an existing built in connection point for the autopilot drive unit. Consult the factory for custom clevis solutions.

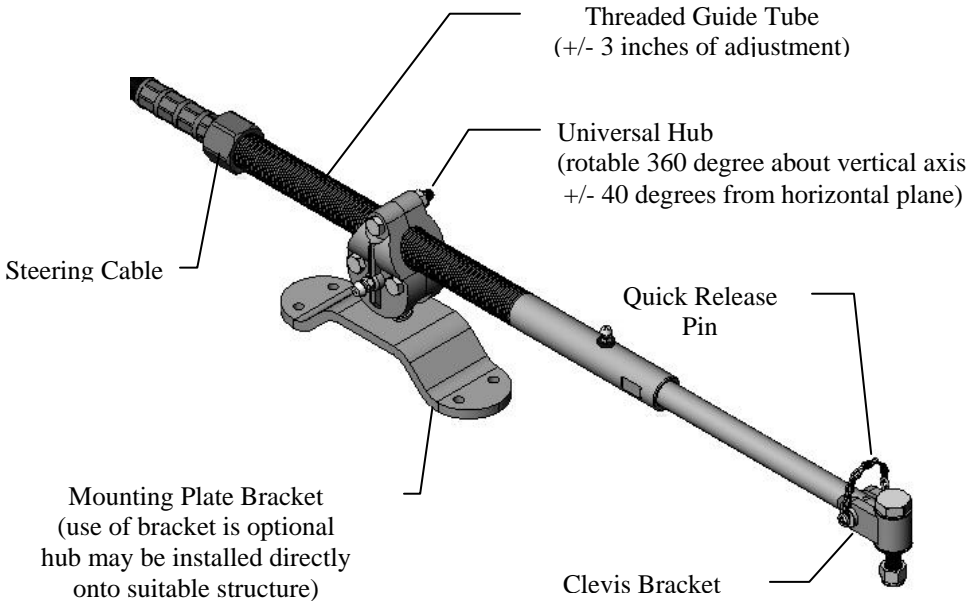

CONNECTION KIT INSTALLATION

B3. STEP 3 – Determine Routing Path for Steering Cable

1. After establishing locations for Connection Kit & Drive Unit. Routing for Steering Cable must be determined.
2. The cable routing should take into consideration the extreme movements of the steering mechanism during HO to HO steering. Maximize the bend radius and minimize the total number of bends. It is recommended that bends are no smaller than the minimum bend radius (6”) and that the total angle of all bends combined be no larger than 270 degrees. See detailed graphic showing preferred routing and bend definition.
3. Steering Cable length supplied with standard system is 6 feet (2 metres). Other lengths are available.

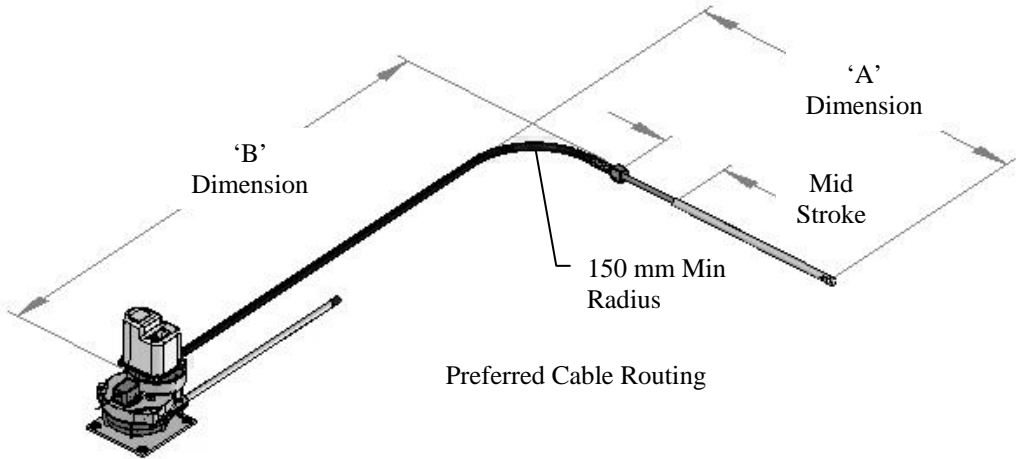

B4. STEP 4 – If Required - Determine Length of Custom Steering Cable

1. If suitable site for drive unit based on a 6 foot steering cable is not available. Use a custom cable length.
2. Use a length of rope or electrical cable to simulate the routing.
3. Measure the total length required. See graphic of cable length definition.

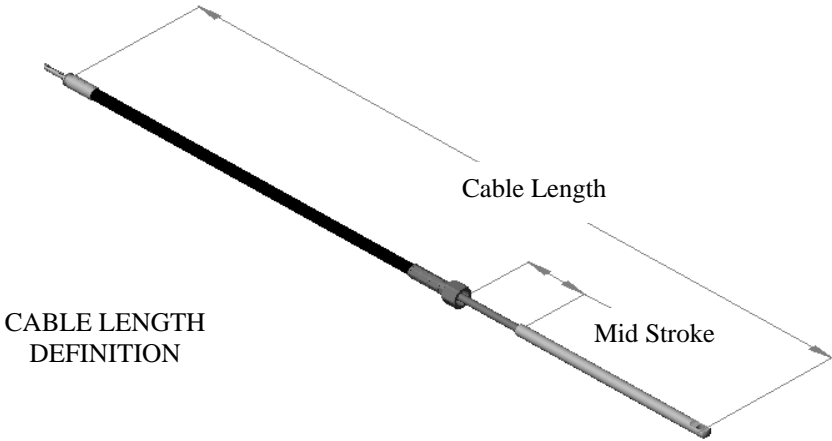

EXAMPLE OF STEERING CABLE LENGTH CALCULATION:

Add 'A' + 'B' dimensions and subtract 4" for a 90 degree bend. Round UP result to nearest full foot size.

For steering cable x length in feet: order OC15211-XX

C. INSTALLATION

C1. Installation of Drive Unit - Steering Cable & Spent Cable Tube

Step 1 - Install Drive Unit

- i. Remove 2 x lock bolts, nuts and washers from ports and retain.
- ii. Position drive unit in final location. Verify position by simulating the steering cable connection whilst steering cable is NOT connected.
- iii. Transfer bolt pattern from the drive base plate (4 x 7 mm diameter holes) into mounting structure.
- iv. Remove drive unit and prepare holes in mounting structure to receive mounting fasteners. Note that this connection does NOT transmit any steering loads.
- v. Re-position drive unit and install fasteners, tighten and torque.

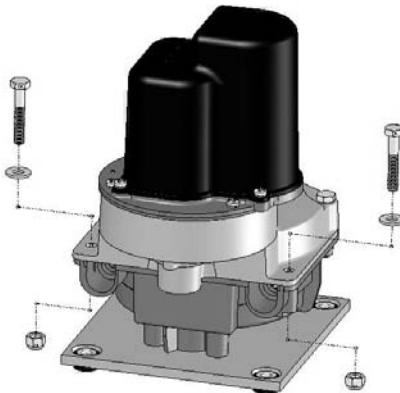

Step 2 - Install Steering Cable

- i. Either port can be used for steering cable entry. The most convenient for the installation should be selected. The spent cable tube attaches to the opposite port. Steering direction can be reversed either by reversing the motor brush leads or by software in the course computer setup.
- ii. Install steering cable into drive port. Guide inner cable into port and exert moderate force using 2 hands to drive cable around the driving hub. This action will back drive the unit and the inner cable will appear out of the opposite port. To complete the cable installation, the cable outer jacket will enter the port and butt against the drive housing. This will enable the insertion of the lock bolt.
- iii. Note that undue force required to drive the inner cable around the driving hub may be caused by the leading edge of the inner cable gouging into outer face of the nylon guide. Remove the cable and inspect the leading edge for sharp edges, if possible, twist the cable and re insert with sharp edge towards inside of radius or using a burr type tool remove the sharp edges.

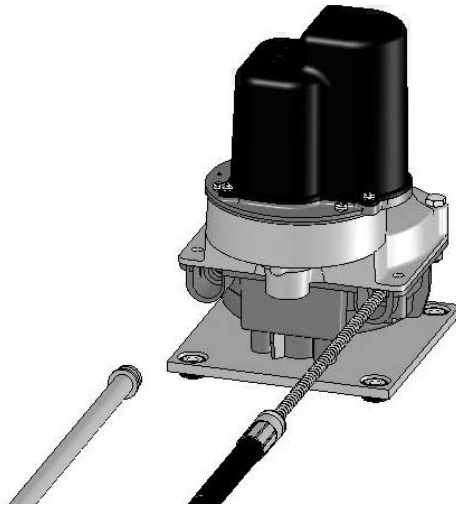

Step 3 - Install Spent Cable Tube

- i. Install spent cable tube in exit port.
- ii. Install 2 x lock bolt, nut and washers into ports. Tighten and torque to 40-45 in-lbs (4Nm).

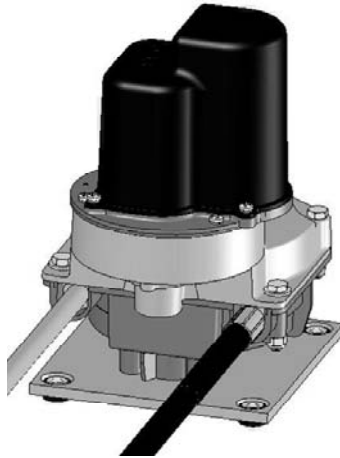

C2: Installation of Cable Connection Kit

The drive system can be fitted into much smaller space than normal linear drives. For optimum performance - closely following the layout shown below is recommended.

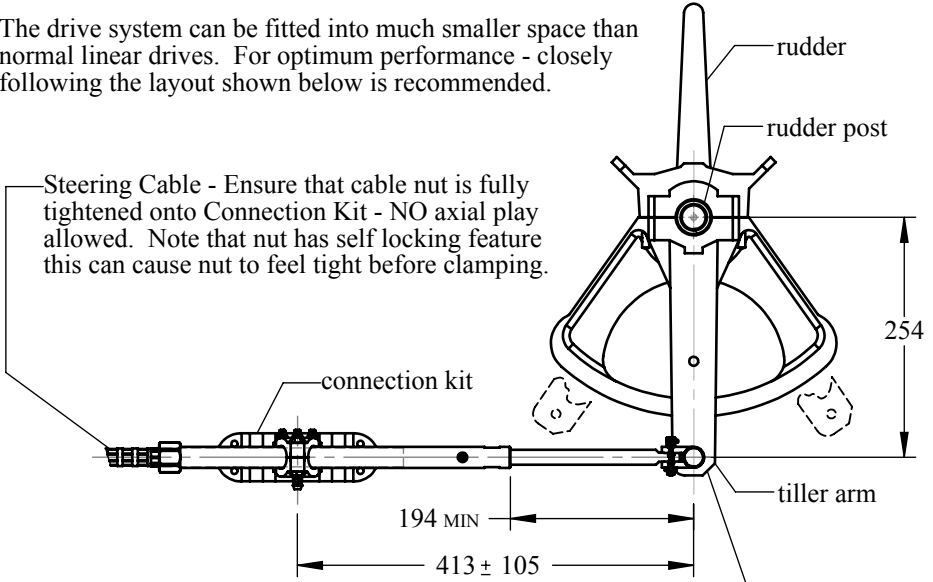

It is desirable that the cable connection kit is set perpendicular to the tiller arm or quadrant at mid stroke - as shown.

shoulder bolt specification
 shoulder \varnothing 11.1 mm - \varnothing 0.44 in
 grip Length 25.4 mm - 1.0 in
 thread neck 0.37-24 UNF x 28 mm - 1.1 in

tiller attach point
 \varnothing 10.0 mm 0.38 in
 thru hole

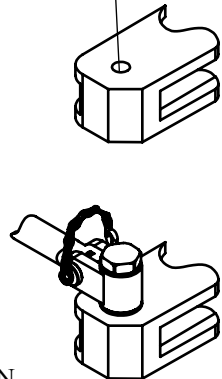
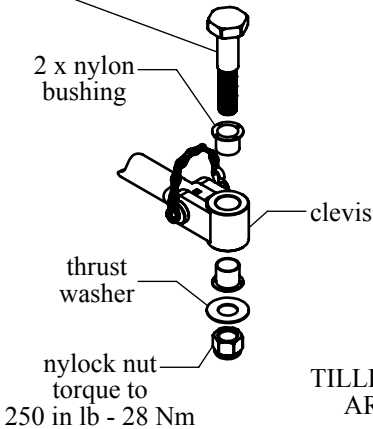

TILLER CONNECTION ARRANGEMENT

OCTOPUS - TYPE RS Sailboat Drive

There are 2 options for mounting the Universal Hub.

Option 1 - Bracket Mounting

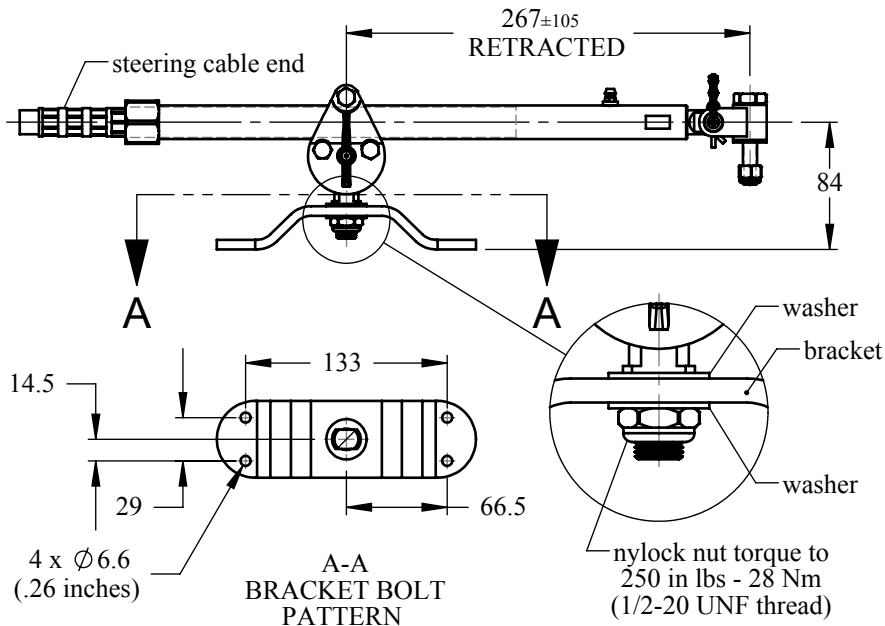

Option 2 - Direct Mounting

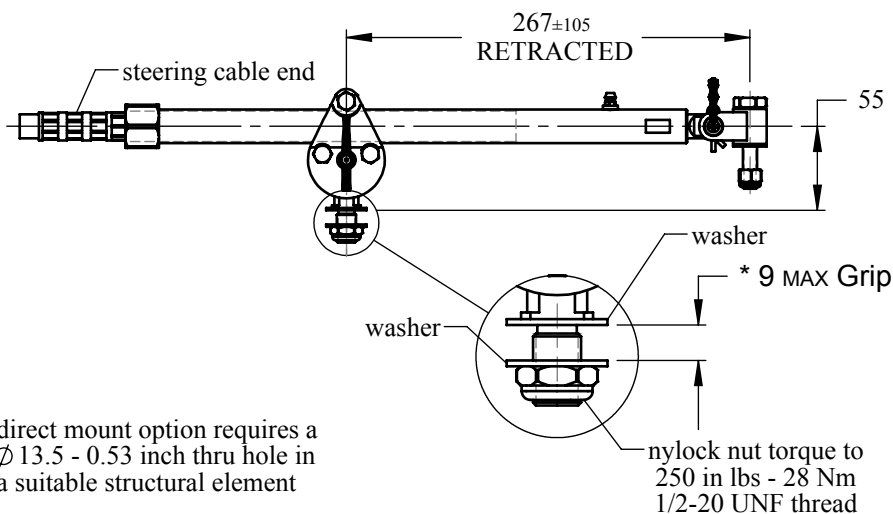

* direct mount option requires a $\varnothing 13.5 - 0.53$ inch thru hole in a suitable structural element

C3. Electrical Connections

Step 1 - Cable Motor and Clutch Power Supply

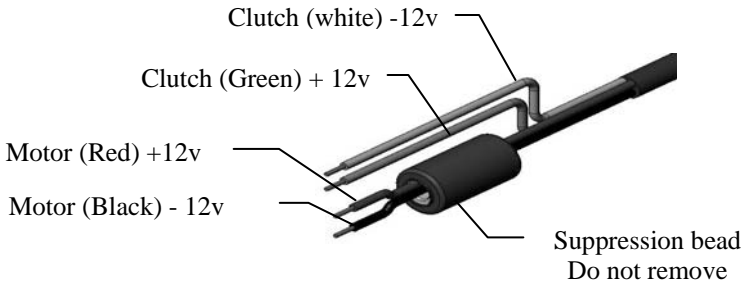

MOTOR & CLUTCH CABLE

- i. Following Auto Pilot installation guide and wiring diagram, connect 4 x 10 AWG wires with Auto Pilot junction box.
- ii. Following Auto Pilot installation guide, perform electrical tests.

Step 2 - Rudder Feed Back Signal Cable

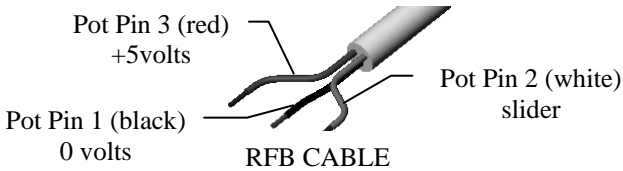

- i. Following Auto Pilot installation guide and wiring diagram, connect 2 x 24 AWG wires + shield core with Auto Pilot junction box. See Hook Up Table for common autopilots
- ii. Following Auto Pilot installation guide, perform electrical tests.

RFB – CABLE HOOK UP TABLE			
OCTOPUS	RAYMARINE	NAVMAN	SIMRAD
Red	Red	Orange	Use OC15222 See Separate Wiring Guide
Black	Blue	Black	
White	Green	Blue	
Shield	Silver	Black	

C4: MECHANICAL CALIBRATION PROCEDURE

1. Disassemble the RFB module from the drive housing, by removing 2 attach screws.
2. Complete the installation of the drive unit into the vessel and install the remote steering cable following the drive installation guide.

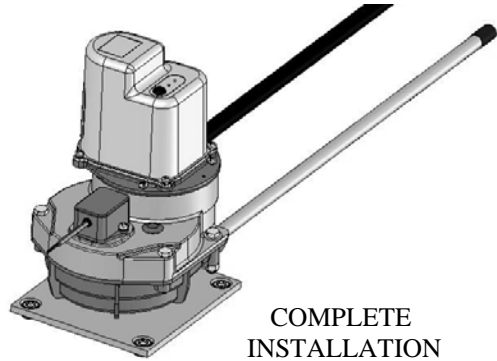

3. Complete the electrical hook up of the drive following the drive-autopilot installation guide.
4. Complete the electrical hook up of the RFB module following the drive-autopilot installation guide.

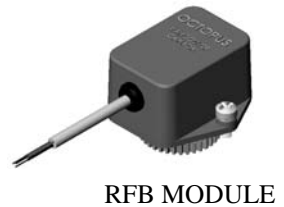

5. Center the gear on the RFB module by aligning the red paint mark on the gear with the red paint mark on the housing as shown in underside view graphic below.

6. By turning the steering wheel of the helm unit, centre the rudder.
7. Reassemble the RFB module to the drive housing and install and tighten the 2 attach screws. Ensure that the mesh between the RFB module and the drive gear is not excessive.

Align 2 red dots vertically

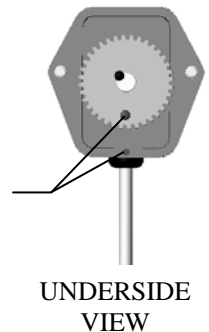

8. See autopilot installation guide for instructions on additional software controlled RFB fine calibration and HO limitation.

D: DOCKSIDE SETUP AND TESTING

Grease the Universal connection kit on Installation by applying a grease gun to grease nipple.

Due to the ‘Manual Release’ safety feature, when the yacht is not in motion it might be required to joggle the wheel/Tiller (move from side to side) to engage or disengage the drive.

E: SEA TRIAL

Before the Autopilot is tested at sea the helmsperson should be made aware of the three safety features and the procedures required.

F: GENERAL MAINTENANCE GUIDE.

Grease the Universal Connection Kit on Installation by applying a grease gun to grease nipple and at regular intervals.

After a few hours of operation and at frequent intervals, check all fasteners and the complete steering system for security and integrity.

Keep all moving parts free from build-up of salt and other foreign material. Build up of salt will affect their operation and create steering problems. Pay particular attention to the Universal Connection Kit. Periodically remove the cable, clean the connector tube and thoroughly lubricate with a waterproof grease.

Inspect periodically for corrosion. Any parts affected by corrosion must be replaced. When replacing hardware, self-locking hardware must be used.

Inspect steering cable periodically for cracks or other damage. If any is found the cable must be replaced.

DO NOT: Cover cracks in the cable outer sheath with tape or other sealant; this will only delay a failure of the cable. Always replace the cable.

G: STEERING CABLE REPLACEMENT

The cable is an accessory item which should be replace at regular intervals as required. The above maintenance procedures should be followed. Recommended cable replacement will be required after 150 -200 hours of use or every two seasons. Note that incorrect installation, high torques or lack of maintenance will affect the life of the cable. For extensive cruising and long passage making; it is recommended that a spare cable is kept onboard.

OCTOPUS - TYPE RS Sailboat Drive

H: Installation Envelope & System Specification

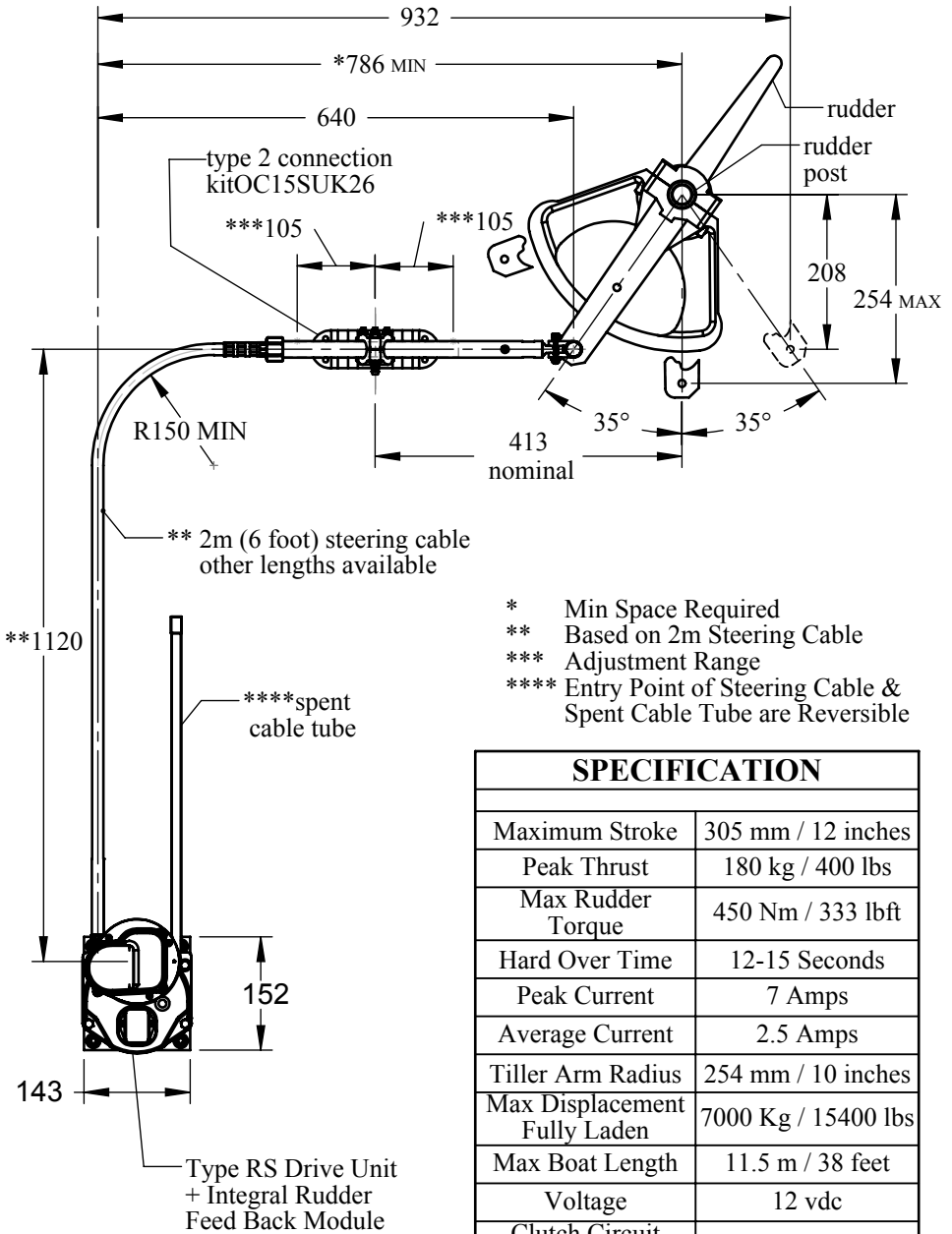

SPECIFICATION	
Maximum Stroke	305 mm / 12 inches
Peak Thrust	180 kg / 400 lbs
Max Rudder Torque	450 Nm / 333 lbft
Hard Over Time	12-15 Seconds
Peak Current	7 Amps
Average Current	2.5 Amps
Tiller Arm Radius	254 mm / 10 inches
Max Displacement Fully Laden	7000 Kg / 15400 lbs
Max Boat Length	11.5 m / 38 feet
Voltage	12 vdc
Clutch Circuit Current	850 milliamps

