



OCTOPUS

DETAIL INSTALLATION GUIDE

REV: A 30 MAY 2008



OC15SUK15A – YAMAHA 115-220 O/B INSTALLATION - KIT

A. SYSTEM OVERVIEW:

1. The Yamaha 115-220 O/B Installation - Kit can be fitted to mechanical push-pull cable steered vessels that are powered by MOST of the popular models of outboard engine. It is recommended for use on vessels with a maximum speed of 40 m.p.h. and should NOT be fitted to vessels where the maximum horsepower of the engine exceeds the maximum horsepower rating for the vessel as stated on the vessel manufacturer's tag.
2. Installation of the kit allows the addition of a second steering cable, which can be used for autopilot control when, connected to the Octopus Remote Mechanical Drive or Jog control when connected to the Octopus Intellisteer remote Mechanical Drive.

B. ENGINE COMPATABILITY:

Suitable for use on YAMAHA 115-220 H.P. from 1984 and newer.
Note that engine has M6 (metric system) threaded holes.

C. REQUIRED PARTS:

1. Part # OC15SUK15A Yamaha 115-220 O/B Installation – Kit
2. Part # OC15109-6 secondary steering cable (6 foot standard – length may vary)
3. General Shop Tools

D. RECOMMENDED INSTALLATION PROCEDURE

D1. Prepare Engine Mounting Site

- i. Using the manual steering helm, centre the engine.
- ii. Ensure that the area immediately in front of the tilt tube is clear of obstructing wires, hoses etc. Re-route if necessary.
- iii. Ensure that the 4 threaded holes on the front face of the tilt bracket are free from paint etc. Re-tap if necessary.

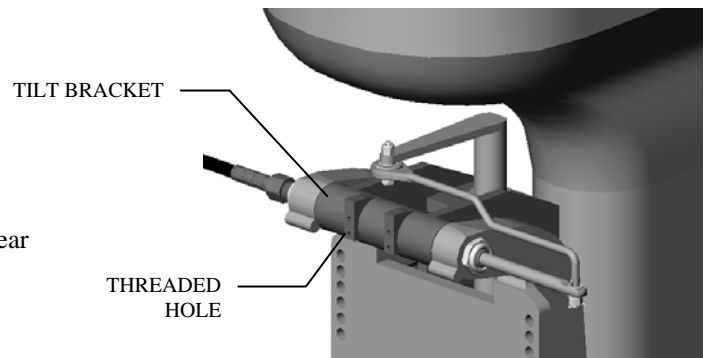

GRAPHIC D1

OCTOPUS PRECISION PRODUCTS - VANCOUVER CANADA
TEL 604 940 2010 - FAX 604 952 2650

DETAIL INSTALLATION GUIDE (continued)
OC15SUK15A - YAMAHA 115-220 O/B INSTALLATION - KIT

D2. Remove Steering Link Arm

- i. To aid the re-assembly procedure, record details of the connections between the Steering Link Arm and the manual steering cable and the tiller.
- ii. Disassemble the connections between the Steering Link Arm and the manual steering cable and the engine tiller. Remove Link Arm.
- iii. **RETAIN** Link Arm and **ALL** connection hardware for re-use.

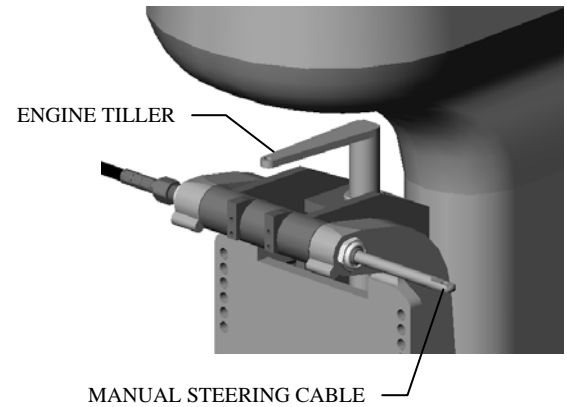

GRAPHIC D2

D3. Pre-assemble Secondary Steering Cable Mount Bracket to Engine Tilt Bracket

- i. Offer Secondary Steering Cable Mount Bracket to Engine Tilt Bracket.
- ii. Install 4 fasteners and lock washers. Torque to 100 in-lbs (11Nm).

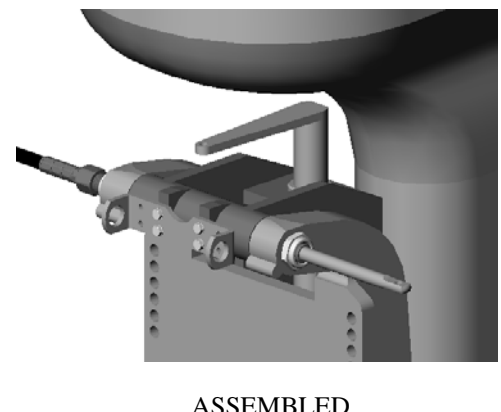
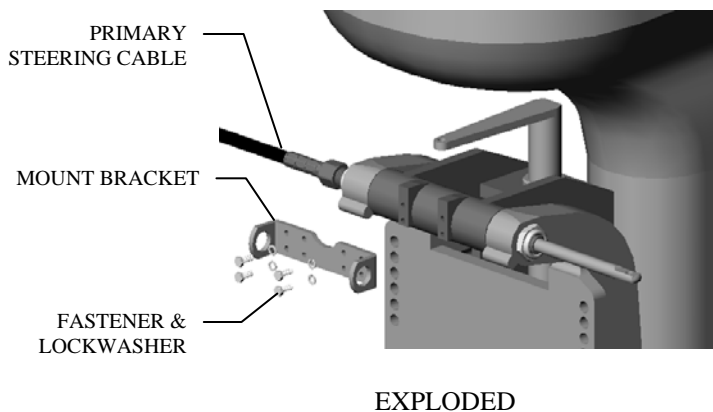

GRAPHICS D3

OCTOPUS PRECISION PRODUCTS - VANCOUVER CANADA
TEL 604 940 2010 - FAX 604 952 2650

DETAIL INSTALLATION GUIDE (continued)
OC15SUK15A - YAMAHA 115-220 O/B INSTALLATION - KIT

D4. Assemble Secondary Steering Cable Guide Tube to Mount Bracket

- i. Ensure that both the lock nuts and the male thread on the Guide tube are lubricated with marine quality grease before assembly.
- ii. Offer Secondary Steering Cable Guide Tube to Mount Bracket and install 2 x lock nuts and grease fitting.
- iii. Adjust axial position of Guide Tube to align EXIT end with the engine tilt tube
- iv. Torque lock nuts/Guide tube to 175 in-lbs (20Nm)

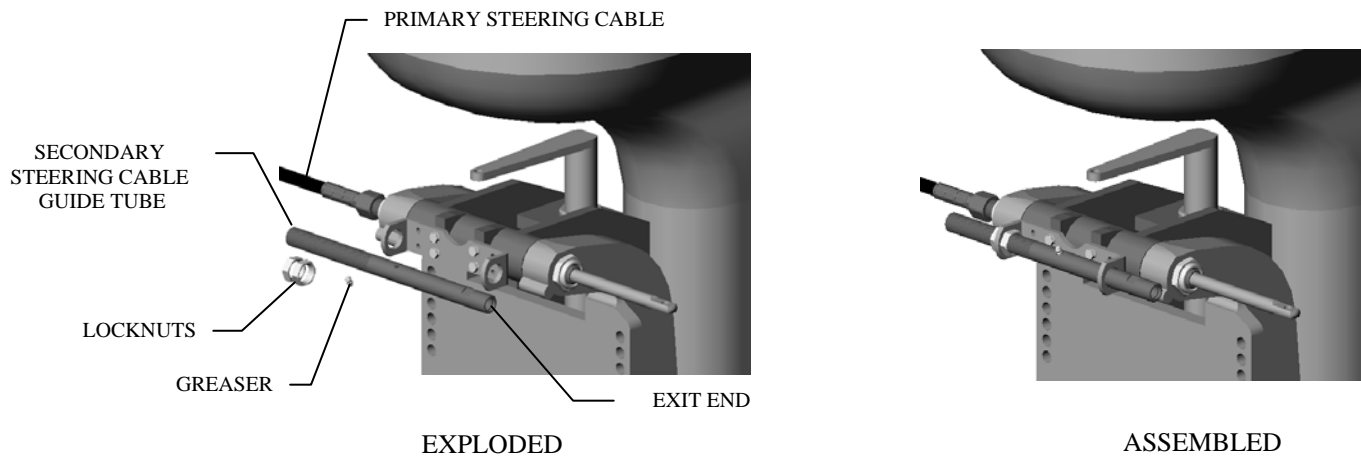

GRAPHICS D4

D5. Assemble Secondary Steering Cable

- i. Ensure that both the nut and the male thread are lubricated with marine quality grease before assembly.
- ii. Ensure that the static portion of the rod end and the inside of the guide tube are liberally coated with marine quality grease.
- iii. Insert the rod end portion of the secondary steering cable into the threaded side of the guide tube assembly.
- iv. Engage 7/8-14 UNF nut on male thread, hand tighten and torque to 175 in-lbs (20Nm). Note that the nut has an internal thread locking feature that can increase the effort required to initial hand tighten.

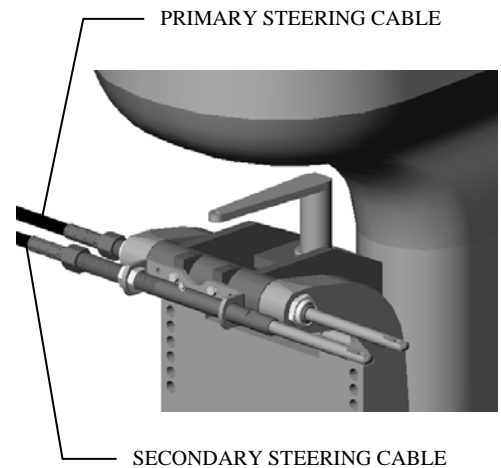

GRAPHIC D5

DETAIL INSTALLATION GUIDE (continued)
OC15SUK15A - YAMAHA 115-220 O/B INSTALLATION - KIT

D6. Assemble Dual Block to Rod Ends of Primary & Secondary Steering Cables

- i. Disassemble 2 x 3/8-24 nuts, cam washer set and 3/8-24 bolts.
- ii. Orientate the Dual Block Horizontally
- iii. Insert 2 x rod ends into the slotted holes of the dual block. Align cross-holes; insert 2 x 3/8 bolt thru both the dual block and the rod ends.
- iv. Assemble 2 x cam washer set and self lock nut. See orientation graphic. Tighten and torque to 180-200 in-lbs.
- v. Ensure that 2 x anti-vibration cam-washer sets are assembled correctly. The serrated face of the washers **MUST** be in contact with the nut face and the dual block face. The cam feature face of the washers **MUST** be in contact with each other.

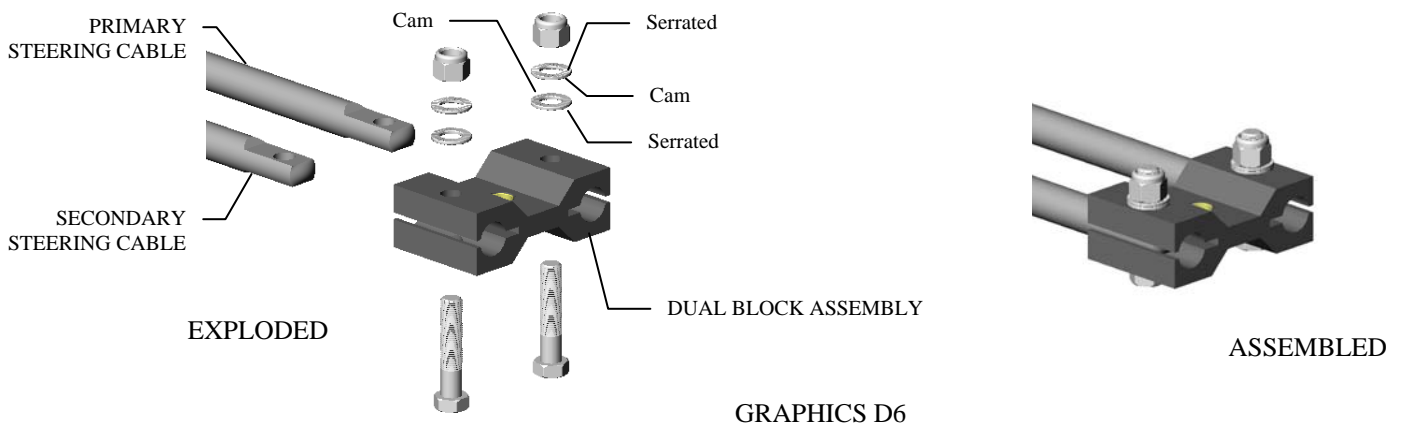

D7. Re-assemble Steering Link Arm

- i. Referring to records established during prior disassembly. Install the Steering Link Arm and secure the connections between the Steering Link Arm and the dual block and the engine tiller.

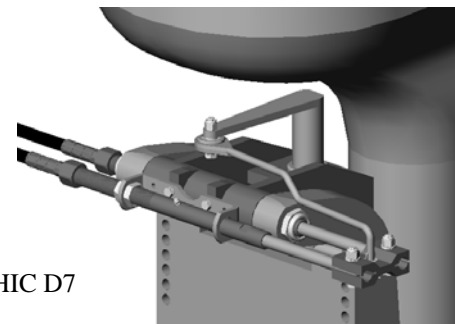

D8. Perform Interference Evaluation (2 people required)

- i. It is extremely important that an **OPERATING CLEARANCE CHECK** be performed between the new O/B Kit & Second Steering Cable and **ALL** adjacent hardware including hoses, electrical cables and control cables.
- ii. With one person operating the manual steering Helm and one-person observing area forward of the engine tilt tube. Slowly run the engine to full HO left and then to full HO right while the observer ensures that there are no physical interferences.
- iii. With engine set at full HO left, tilt engine into full up position, ensure that there are no physical interferences. Repeat with engine set to full HO right.
- iv. It may be necessary to re-rout hoses, electrical cables or control cables. **ALL** hardware must be well clear of the new O/B Kit and Second Steering Cable. Note that chaffing can occur if parts are allowed to come into contact.