



# OCTOPUS

SELECTION & INSTALLATION GUIDE  
Rev. C



## CRA SERIES CONTINUOUS RUNNING PUMPSET

### A. GENERAL DESCRIPTION:

Octopus CRA continuous running pumps are very reliable quiet and efficient devices which will give you thousands of hours of trouble free service. They are based upon a continuously running D.C. motor driving a gear pump and are used for autopilot drive service on larger yachts and small commercial vessels. They can be used on steering cylinders up to 1000 cc (60 cu in) in volume. For serviceability, the design is based upon modular construction enabling either a motor module or a pump module to be easily changed with no special skills. They also feature a built in motor starter relay, a running light to indicate to the operator that the unit is on, a shut off valve to enable isolation of the pump from the steering system and have no external plumbing. When selecting a flow rate to drive your specific steering cylinder you should aim to operate the rudder from full left hard over to full right hard over in about 15 seconds. Note that the pump is designed to power on and run when the autopilot is powered on, when started up it will only deliver about 80% of rated capacity and use slightly more power. Full rated capacity will be attained about 30 minutes after starting when the pump has warmed up.

### B. BASIC MODELS

CRA pumpsets are available in any combination of 3 flow rates and 2 voltages. For example in model CRA0212, the first 3 characters signify a CRA pump type, the fourth & fifth characters signify 2 liter/min (0.50 gpm) flow rate and the sixth & seventh characters signify 12 vdc motor and control coils. Other flow rates are 3 liter/min (0.75 gpm) and 4 liter/min (1.00 gpm). Other voltage is 24vdc.

#### B1. BASIC OPTIONS AVAILABLE ON ANY CRA PUMPSET

- i. **PRESSURE GAGE:** A pressure gage can be fitted to show steering pressures. Signified by suffix P in model #.
- ii. **PRESSURE RELIEF VALVE:** Adjustable from 50 to 1200 p.s.i. (4 to 85 bar). Signified by suffix R in model #. The cartridge valve for this option is shipped loosely packaged and a blanking plug is installed in the port. See section G for assembly instructions.

#### B2. SPECIAL OPTION AVAILABLE ON CRA 02 LITRE PUMPSETS ONLY

- i. **FLOW CONTROL:** This feature allows the flow to be adjusted from the maximum of 2000cc/min down to 1300cc/min (0.5 gpm down to 0.3 gpm). Signified by suffix F in model #.

### C. MECHANICAL INSTALLATION:

Mount the pump anywhere in the vessel where it is close to the tubes connecting the hand steering helm pump to the rudder cylinder. Preferably this should be on a horizontal surface in a clean dry area. The best location is usually in the engine room. There are 4 attachment holes with rubber isolators and brass ferrules in the base plate, use 4 x 1/4 bolts. Be careful to mount the pump with the shut off valve (with 3 brass screws) facing outwards for easy service, and to allow enough clearance above the unit to give access for filling with oil. The unit will generate up to 150 watts of heat, so avoid installing it in a poorly ventilated area.

**OCTOPUS PRECISION PRODUCTS - VANCOUVER CANADA**  
**TEL 604 940 2010 - FAX 604 952 2650 – website octopusmarine.ca**

## CRA SERIES CONTINUOUS RUNNING PUMPSET(continued)

### D. HYDRAULIC CONNECTIONS:

In any hydraulic system it is important to use flexible hoses between the pump and the copper tubing to protect the tubing against fatigue. The pump is supplied with a shut off manifold, this manifold has 3 pairs ports tapped 1/4" N.P.T. in front face and top face. You can choose one and plug the other one. It is most important to keep all dirt, including dust, out of the system during installation. Blow out all hydraulic lines before assembly. Ensure **ADEQUATE** venting/drainage of reservoir as recommended below.

There are different configurations of connections Figs showing below:

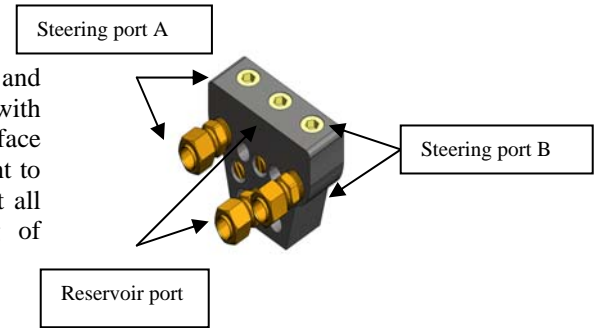

Upper ports



Front ports



Typical random ports

**ALL 3 HYDRAULIC LINES + ADDITIONAL VENT DRAIN LINE (AS SPECIFIED BELOW) MUST BE USED**

### D1. CONNECTING THE 2 PRESSURE LINES:

With the pump mounted on a horizontal surface, the 2 steering ports on the shut off valve must be connected to the tubes connecting the hand steering helm pump to the rudder cylinder.

### D2. CONNECTING THE VENT/DRAIN LINES:

For venting and draining, the reservoir port on the shut off valve **MUST** be connected to the existing reservoir on the steering system. This is usually a separate pressurized reservoir tank (on a pressurized system) or the steering helm itself (on an unpressurized system). There is usually a port on the bottom of the helm pump. If there are 2 helm stations, use the most convenient. If the pump is being installed on a steering system that is power assisted, it is strongly recommended that an **ADDITIONAL VENT/DRAIN LINE** be connected between one of the ports on the pump reservoir and the existing steering system reservoir. The correct installation of these **VENT/DRAIN LINES** is crucial for the operation of the pump & protecting the reservoir from structural damage due to momentary over pressurization.

Note:

1. Ensure that the existing hydraulic system incorporates non-return (lock out) valves in the helm pump (check with the steering system manufacturer); if it does not, then suitable valves must be fitted. Most North American steering systems have non-return valves.
2. A suitable liquid pipe thread sealer may be used sparingly. Do not use plastic or PTFE tape, this can very easily separate and allow fragments into the system.
3. **DO NOT RUN THE PUMP WITHOUT SUITABLE VENTING - THIS WILL CAUSE DAMAGE.**
4. When installing the pump on a pressurized steering system (like Hynautic), the vent/drain line **MUST** be connected to the pressurized reservoir tank (the reservoir tank compensates for fluid expansion).

**OCTOPUS PRECISION PRODUCTS - VANCOUVER CANADA**  
**TEL 604 940 2010 - FAX 604 952 2650 – website octopusmarine.ca**

## **CRA SERIES CONTINUOUS RUNNING PUMPSET(continued)**

### **E. FILLING THE SYSTEM:**

To fill the system you will need a 3/8 AF allen key and a 5/16 wide plain blade screwdriver. After installing the Octopus CRA Pump the steering system can be filled following the following procedure:

- i. From fully closed, open the 3 brass screws on the shut off valve 2 full turns each using screwdriver.
- ii. Remove the port plugs on the pump tank, using one as filler and one as breather, fill tank with clean hydraulic oil or automatic transmission fluid as recommended by your steering system manufacturer. Replace both plugs and tighten.
- iii. Fill the steering system following the steering system manufacturers recommended procedure.
- iv. If the steering system is of the non-pressurized type, ensure that a vented plug is installed in the expansion tank of the uppermost steering station. **IF THE UPPERMOST STEERING STATION IS NOT VENTED - THE CRA PUMP WILL BE DAMAGED.** Fluid expansion is catered for through the vented plug.
- iv. If the steering system is of the pressurized type, re-pressurize the system to the lowest pressure level that allows purging. Higher pressure in the steering system (above what is needed to purge) is unnecessary and will reduce the life of system seals. Fluid expansion is catered for within the pressurized system reservoir.

### **F. ADJUSTING PUMP FLOW (CRA-02 OPTION ONLY):**

To adjust the flow you will need a 3/4 AF wrenches and a 1/4 AF allen key. The CRA pump is shipped set at it's maximum rated flow, the cartridge style flow control valve is located on top of the pump towards the rear. (When facing the front of the pump, you will see the shut off valve and running light). This valve has an adjusting screw with a lock nut. To make flow adjustments:

- i. Using both the wrench and the allen key, crack the lock nut on the adjusting screw.
- ii. Using the allen key, turn the adjusting screw clockwise (in) to reduce flow to desired setting.
- iii. After achieving desired setting use wrench and allen key to re-tighten the lock nut.
- iv. Be careful not to unscrew the whole cartridge body during this procedure.
- v. You cannot over or under adjust the adjusting screw; there are definite stop points.
- vi. It may be necessary to try several settings to get the best autopilot performance.

### **G. ASSEMBLING CARTRIDGE VALVE & ADJUSTING PRESSURE RELIEF SETTING (OPTION):**

To adjust the pressure relief setting you will need a 3/4 AF wrench and a 1/4 AF allen key.

The cartridge style pressure relief valve is located at the rear of the pump. When facing the front of the pump, you will see the shut off valve and running light. This pressure relief valve cartridge has an adjusting screw with a lock nut. The valve cartridge is packaged loosely during shipping, screw in the cartridge valve and torque to approx 30 inlbs using the 1" wrench. The cartridge valve is preset at 600 p.s.i. To make pressure relief adjustments:

- i. Using both the wrench and the allen key, crack the lock nut on the adjusting screw.
- ii. Using the allen key, turn the adjusting screw clockwise (in) to increase pressure relief setting or counterclockwise (out) to decrease pressure relief setting.
- iii. After achieving desired setting use wrench and allen key to re-tighten the lock nut.
- iv. Be careful not to unscrew the whole cartridge body during this procedure.
- v. You cannot over or under adjust the adjusting screw; there are definite stop points.

## **H. ELECTRICAL CONNECTIONS:**

You will need a 1/8 inch wide plain blade screwdriver and a 5mm AF allen key, before making any connections, ensure that the supply voltage matches the pump voltage as identified on the specification plate on the end of the electrical cover. When facing the front of the pump, you will see the shut off valve and running light, the electrical cover is on the left side of the pump and has 2 cable penetrations in it on the rear side, the hydraulic oil reservoir is on the right, it has 2 plugged ports on the top. To make electrical connections:

- i. Using the allen key, crack and remove the 4 allen screws holding the electrical cover to the center manifold. **DO NOT LOOSEN THE HYDRAULIC OIL RESERVOIR.**
- ii. Pull off the electrical cover, as it seals on an 'O' ring, a firm pull is required.
- iii. Feed the connecting cables through the 2 penetrations in the electrical cover. The motor power cables go thru the outermost hole, the control cables from the autopilot go thru the innermost hole.
- iv. The motor power cables must be a minimum of 16 AWG.
- v. Connect the cables using the screwdriver, as shown in wiring diagram A or B attached.
- vi. Run electrical tests as per procedure in section I below.
- vii. Replace electrical cover with a firm push to overcome the 'O' ring friction, ensure correct alignment.
- viii. Install and tighten the 4 allen screws using the allen key.

## **I. STARTING AND TESTING:**

Before testing the pump, ensure that the 3 brass screws on the shut off valve are open by 2 full turns from fully closed. The electrical cover can be left off for this test. To test the pump:

- i. Turn on the supply power to the motor at terminals 1 & 2.
- ii. Turn on the supply positive power to the starter relay at terminal 3, this is usually switched by an output terminal on the autopilot becoming positive when the pilot is turned on. The negative terminal 4 being jumpered across to motor negative terminal 2.
- iii. The pump motor will start and run with a smooth hum, the running indicator light will turn on confirming that the motor is running and that polarity is correct. If the motor runs and the running indicator light does not come on, the polarity is incorrect.
- iv. To test for steering control, momentarily energize first terminals 5 & 6 and note that the motor noise will change slightly and the rudder will move in one direction. To test for opposite rudder direction momentarily energize terminals 7 & 8. This test can be achieved by using jumper cables from terminals 1 & 2 or by using autopilot controls as per autopilot manufacturers instructions.
- v. During these tests avoid running the rudder into the stops.
- vi. On completion of testing, replace electrical cover as per section H procedure above.

## CRA SERIES CONTINUOUS RUNNING PUMPSET(continued)

### J. MAINTENANCE:

You will need a 1/4 AF , a 5/16 AF and a 5-mm AF allen key. To ensure longer life it is recommended that at about one year intervals the following cleaning procedure be performed:

- i. Drain the hydraulic oil out of the complete steering system. There is a drain plug on the front of the pump below the running light, crack and remove this using the 1/4 AF allen key. Ensure adequate venting whilst removing the old oil. To completely remove the old oil, you may have to remove additional plugs depending on your system.
- ii. Using the 5 mm AF allen key, crack and remove the 4 allen screws holding the hydraulic oil reservoir to the center manifold. **DO NOT LOOSEN ELECTRICAL COVER.**
- iii. Pull off the hydraulic oil reservoir, as it seals on an 'O' ring, a firm pull is required.
- iv. Removal of the reservoir will expose a filter basket, unscrew this basket from the elbow and clean off the filter mesh.
- v. Re-attach the basket to the elbow, ensuring that basket is pointing towards the bottom of the reservoir.
- vi. Clean the inside of the reservoir including the small magnet, which may have trapped magnetic particles.
- vii. Replace the hydraulic oil reservoir with a firm push to overcome the 'O' ring friction, ensure correct alignment.
- viii. Install and tighten the 4 allen screws using the 5-mm AF allen key.
- ix. Install and tighten the drain plug using the 1/4 AF allen key.

### K. TROUBLESHOOTING:

If the unit fails to operate after installation is complete, check for the following common causes.

#### 1. Motor does not run:

- i. No voltage applied to motor. (check voltage at motor with voltmeter).
- ii. Check power supply and circuit breaker.
- iii. Check starter relay.
- iv. Autopilot not switched on correct setting. (check autopilot manual).
- v. Check motor brushes.

#### 2. Motor runs but solenoid valve does not operate:

- i. System not filled with oil. (fill system).
- ii. Shut off valve closed. (open needle valves 2 full turns each).
- iii. Check motor polarity - running light will not come on if polarity is incorrect.
- iv. Hydraulic connection incorrect. (check that 2 side hoses from shut off valve connect to cylinder hoses).
- v. Vent/Drain line (top hose on shut off valve) not connected. (Must connect to reservoir).
- vi. Check that switching power is reaching solenoids.
- vii. Check solenoid coil continuity.
- viii. Dirt in solenoid valve. (see item 4 below).

#### 3. Deformed lugs on pump reservoir at connection with center manifold, resulting in leak of hydraulic fluid.

This condition is caused by excessive pressure build up in pump reservoir from return steering line. Ensure reservoir is vented as per section D2. If the lugs are deformed, you must remove the reservoir and either replace or repair it.

## CRA SERIES CONTINUOUS RUNNING PUMPSET(continued)

4. Dirt in the solenoid valve will cause excessive power consumption and solenoid valve failure. This condition may be detected by small rise in the operating pressure when the unit is running at idle. This condition will eventually stop the pump from steering and therefore must be rectified as soon as possible. To replace or clean the solenoid valve:
- i. Close the 3 brass needle valves on the shut off valve on the front of the pump.
  - ii. Crack and remove the 4 allen screws holding the shut off valve to the pump body.
  - iii. Disconnect the electrical power and control lines from the unit.
  - iv. Remove the unit from the vessel.
  - v. Drain the pump reservoir and then remove reservoir (see section J above).
  - vi. Wash out the reservoir and filter basket and re-assemble to pump.
  - vii. Remove the electrical cover (see section H above).
  - viii. Remove the solenoid valve coils, note the position of washers between the coils.
  - ix. Unscrew the solenoid valve from the pump body.
  - x. Wash the valve with varsol and blow dry with compressed air. If this procedure does not clear away the blockage, it is recommended that a new valve cartridge is fitted.
  - xi. Re-assemble cartridge valve.
  - xii. Re-assemble solenoid valve coils, ensuring correct position of washers between coils.
  - xiii. Re-install unit to vessel, connect electrical power and control lines, connect shut off valve ensuring that the 3 'O' rings are in position between shut off valve body and pump body.
  - xiv. Fill system with oil as per section E above, start and test as per section I above.

### L. SPARE PARTS :

The following parts are available as spares and are recommended for vessels undertaking extensive passages or when autopilot downtime must be kept to an absolute minimum. Specify serial number of pump when ordering.

1. 12v Motor Module	pt # OC19SUK01	7. Solenoid Valve Cartridge	pt # OC1920
2. 24v Motor Module	pt # OC19SUK02	8. 12v Solenoid Valve Coil	pt # OC1713
3. Pump Module Kit 2L	pt # OC19SUK06	9. 24v Solenoid Valve Coil	pt # OC1714
4. Pump Module Kit 3L	pt # OC19SUK07	10. 12v Motor Starter Relay	pt # OC1912
5. Pump Module Kit 4L	pt # OC19SUK08	11. 24v Motor Starter Relay	pt # OC1913
6. Seal Kit	pt # OC19SUK09		

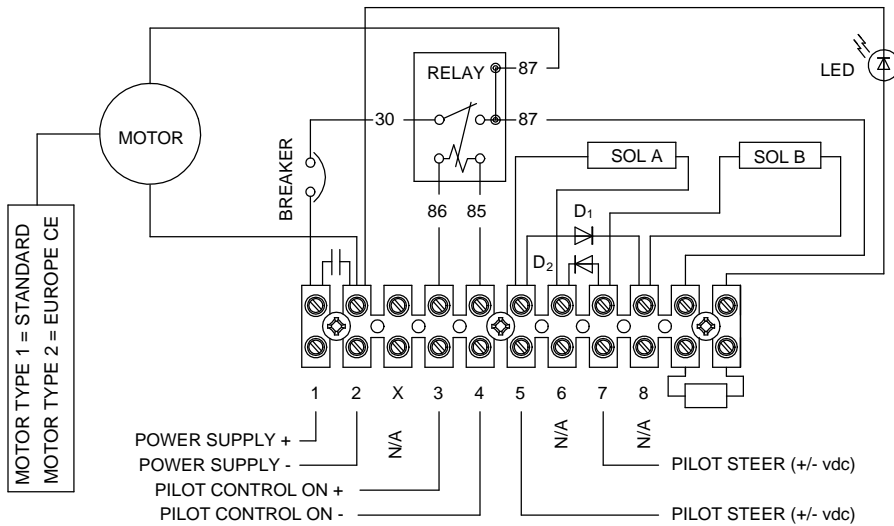

MOTOR TYPE 1 = STANDARD  
MOTOR TYPE 2 = EUROPE CE

**DIAGRAM C**

FOR 12 OR 24 VOLT SYSTEMS  
WITH REVERSING POLARITY  
OUTPUTS FROM AUTOPILOT

RESISTOR R1 FOR 12V = 330 Ohms / 0.5 Watts  
RESISTOR R1 FOR 24V = 680 Ohms / 1.0 Watts  
DIODES D1 & D2 = 1 AMP / 100 VOLT  
CAPACITOR C1 FOR 12V & 24V = 100nF / 100V  
EUROPEAN DELIVERY CE SPEC ONLY

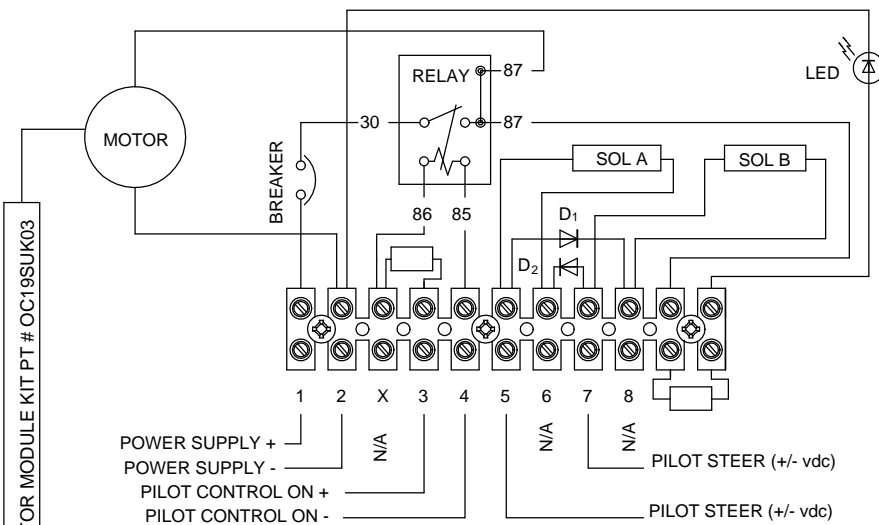

32v MOTOR MODULE KIT PT # OC19SUK03

**DIAGRAM D**

FOR 32 VOLT SYSTEMS  
WITH REVERSING POLARITY  
OUTPUTS FROM AUTOPILOT

RESISTOR R1 = 1.0 K Ohms / 2.0 Watts  
RESISTOR R2 = 180 Ohms / 2.0 Watts  
DIODES D1 & D2 = 1 AMP / 100 VOLT

**Octopus Precision Products**

660 DERWENT WAY, DELTA, B.C. V5M 5P8, CANADA  
TEL 604 525 0471 FAX 604 524-9671

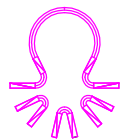

DATE APR 99	DRAWN T.Z.	SCALE NONE	INS. # OC190001	REV A
----------------	---------------	---------------	--------------------	----------

FILE # OC1963	TITLE <b>WIRING DIAGRAMS CRA PUMP</b>
------------------	--