



# OCTOPUS

SELECTION & INSTALLATION GUIDE



## UNBALANCED VALVE ACCESSORY KIT – OC17SUK03

### SELECTION:

The unbalanced valve accessory is a pilot operated bleed valve. It is used with an Octopus reversing pump when the steering cylinder fitted to the vessel is unbalanced. In use the bleed valve equalizes the amount of hydraulic oil that is returned to the pump from the high volume side of the cylinder to the amount of oil that is being pumped to the low volume side.

### DEFINING UNBALANCED - BALANCED CYLINDERS:

#### The cylinder is unbalanced:

If, when the cylinder is fully retracted, the cylinder shaft extends from the front of the cylinder only.

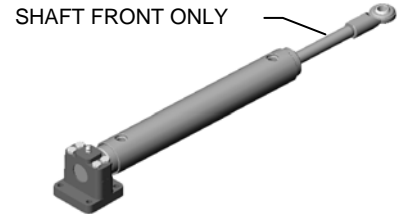

UNBALANCED CYLINDER  
USE OC17SUK03 UB VALVE

#### The cylinder is balanced:

If the cylinder shaft extends from both the front and the rear of the cylinder; it is a balanced cylinder.

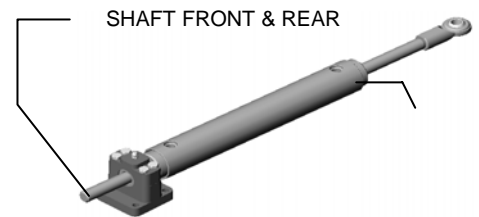

BALANCED CYLINDER

### CALLIBRATION:

The UB Valve ships from the factory calibrated and ready for use. However it is recommended that the adjustment screw settings are checked before installing the valve. See the setting diagram below.

Note: Do **NOT** unscrew the brass screws out of valve body as permanent damage will be caused. Also do **NOT** operate the system with the brass screws fully tightened as this will cause flow restrictions and cause the motor to draw more electrical current.

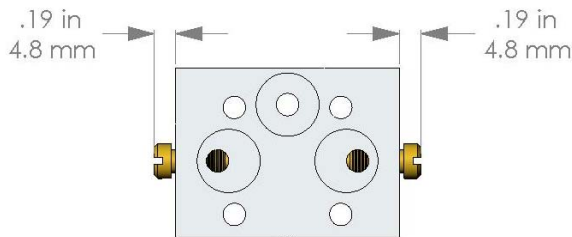

FULLY TIGHTENED  
(DO **NOT** OPERATE AT THIS SETTING)

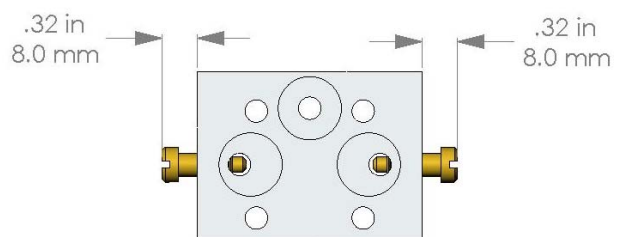

CALIBRATED  
(OPERATE AT THIS SETTING)

### VALVE ADJUSTMENT SCREW SETTINGS

OCTOPUS PRECISION PRODUCTS - VANCOUVER CANADA  
TEL 604 940 2010 - FAX 604 952 2653 – website octopusmarine.ca

## UNBALANCED VALVE ACCESSORY KIT – OC17SUK03 - Continued

### INSTALLATION:

The valve body fits sandwich style between the front face of the pump body and the rear face of the manifold. 4 pieces of M5 x 30mm allen screws are used to secure this sandwich assembly. The UB valve has 3 ports that align with the existing ports on the pump body and manifold, these ports are sealed with "O" – rings. A total of 6 "O" - rings are required – 3 front & 3 rear. Note that older style pump modules (Gen I) require a different set of "O" rings than the new (Gen II) pump modules. All "O" rings and allen screws are supplied in the kit. See Graphics.

#### Typical Gen I Pump Installation:

Note Parts List:

1 x UB Valve  
6 x # 013 "O" rings  
4 x M5 x 30 allen screws  
"Hockey Puck" style NPT SV manifold Shown  
(UB Valve can be used with all other manifolds)

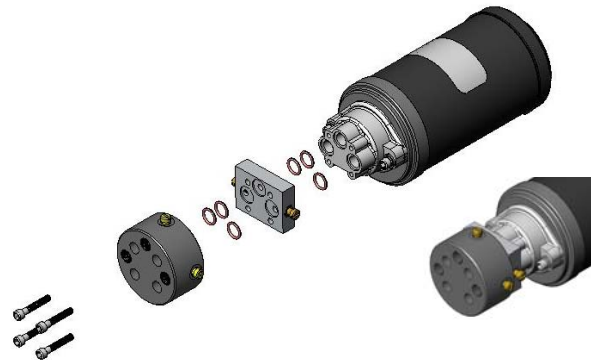

#### Typical Gen II Pump Installation:

Note Parts List:

1 x UB Valve  
3 x # 013 "O" rings  
2 x # 012 "O" rings  
1 x # 017 "O" ring  
4 x M5 x 30 allen screws  
"Universal" style NPT SV manifold Shown  
(UB Valve can be used with all other manifolds)

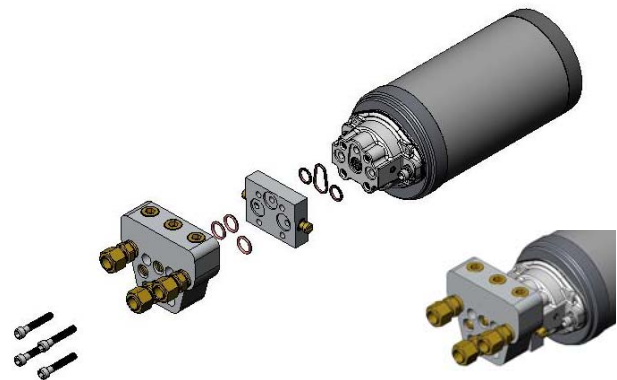

### SPECIFICATION:

The valve will operate on all Octopus reversing pumps 1L thru 2L per min. There are no threaded ports to match.